



BRAKE PIPE FLARING KIT - TURRET TYPE

MODEL NO: PFT07.V2

Thank you for purchasing a Sealey product. Manufactured to a high standard, this product will, if used according to these instructions, and properly maintained, give you years of trouble free performance.

IMPORTANT: PLEASE READ THESE INSTRUCTIONS CAREFULLY. NOTE THE SAFE OPERATIONAL REQUIREMENTS, WARNINGS & CAUTIONS. USE THE PRODUCT CORRECTLY AND WITH CARE FOR THE PURPOSE FOR WHICH IT IS INTENDED. FAILURE TO DO SO MAY CAUSE DAMAGE AND/OR PERSONAL INJURY AND WILL INVALIDATE THE WARRANTY. KEEP THESE INSTRUCTIONS SAFE FOR FUTURE USE.



Refer to instruction manual

1. SAFETY

- WARNING!** Ensure Health & Safety, local authority and general workshop practice requirements are adhered to when using this equipment. Familiarise yourself with the application and limitations, as well as the potential hazards of the kit.
- ✓ Maintain the kit in good condition. Replace or repair damaged parts. Use genuine parts only. Unauthorised parts may be dangerous and will invalidate the warranty.
- ✓ This kit is suitable for flaring copper, brass, steel or thin walled aluminium pipe.
- ✓ Locate the flaring tools in a suitable work area, keep the area clean and tidy and ensure there is adequate lighting.
- WARNING!** Always wear approved eye or face protection when using the flaring tools.
- ✓ Keep children and unauthorised persons away from the working area.
- ✗ **DO NOT** use the kit for any purpose other than for which it is designed.
- ✗ **DO NOT** use the kit if any parts are damaged or missing as this may cause failure and/or personal injury.
- ✗ **DO NOT** allow untrained persons to use the kit.
- ✗ **DO NOT** attempt to flare piping when you are tired, under the influence of alcohol, drugs or intoxicating medication.
- ✓ When not in use clean kit components, replace in case and store in a safe, dry, childproof area.
- ✓ **REMEMBER!** The safe operation of a vehicle, or other equipment, may well depend on the quality of the flare produced. Discard any flare which is mis-formed.
- WARNING!** The warnings, cautions and instructions discussed in this manual cannot cover all possible conditions and situations that may occur. It must be understood that common sense and caution are factors which cannot be built into this product, but must be applied by the operator.

2. INTRODUCTION

Produces accurate automotive double flares on most common sizes of brake pipe. Cam-action body mounts in bench vice for ease of use. Includes dies and clamp blocks for forming most popular flares. Optional 3/8" clamp block available. Supplied in storage case.

3. SPECIFICATIONS

Model no PFT07.V2
Dies:.....3/16", 1/4", 5/16", 3/8", 8mm DIN
Clamp blocks3/16", 1/4", 5/16", 4.75mm
Optional clamp block.....3/8" (PFT07.04)

4. OPERATION

- WARNING!** Before using the flaring kit, ensure that you have read and understood the Safety Instructions in Section 1. Ensure you are familiar with the various types of flares before using this equipment.

4.1. PREPARATION OF THE BRAKE PIPE

- 4.1.1. The end of the pipe must be cut square.
- 4.1.2. The outside edge of the pipe must be chamfered approx 0.25mm X 45°
- 4.1.3. The bore of the pipe must be de-burred.
- 4.1.4. If the pipe is plastic covered, this must be removed for 3mm from the end of the pipe to be flared. Ensure the pipe is not scored or any metal removed during the operation. **DO NOT** use abrasive cloth. Blow any debris from the pipe after flaring.
- 4.1.5. Clamp the tool in a suitable bench mounted vice. Assemble the lever onto the cam as shown. Loosen the clamping screw to allow the clamp to swing open.
- 4.1.6. The pipe end to be flared must be cut clean and square and be de-burred. Use a pipe or tube cutter (available from your Sealey stockist).

- 4.1.7. Consult Chart 1 and select the die specified to produce the required flare. Place the die into the cavity as shown with the split line horizontal and the counter bore towards the operating lever (fig.1).

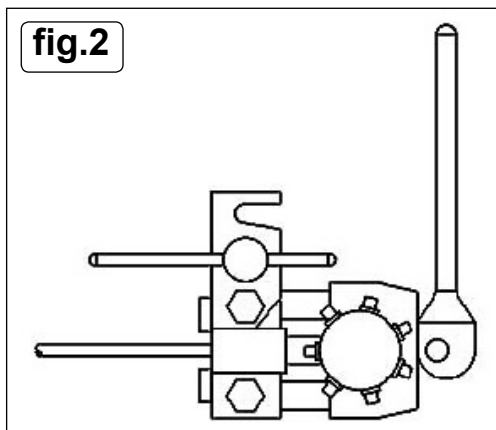
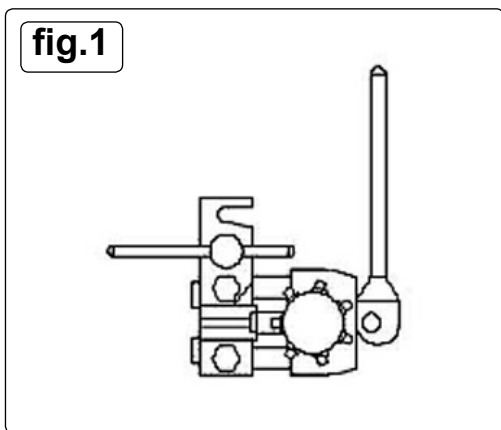

- 4.1.8. After the pipe has been prepared as instructed above, ensure the tube nut is fitted to the pipe. Pass the pipe through the rear of the die until the prepared end is flush with the front face of the die. Ensure that both halves of the die are contacting the die stops (fig.2). Swing the locking plate into position and tighten the clamping screw. Check that the position of the pipe and die are still correct.

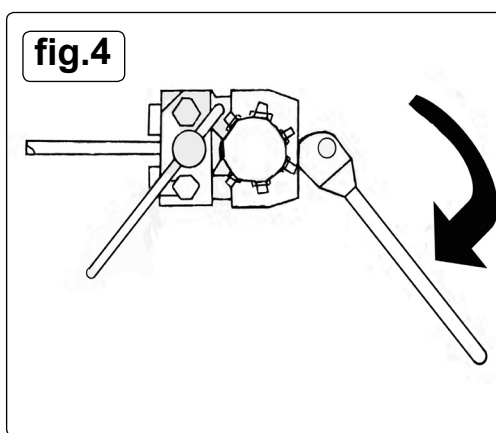
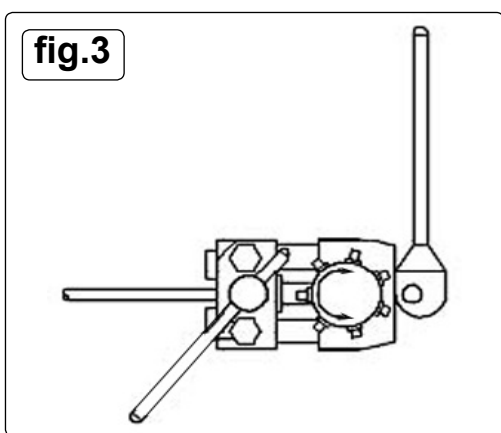

- 4.1.9. Select required OP.1 punch by rotating the turret so that it is facing and in line with the pipe, fig.3.
- 4.1.10. Pull the lever to engage the punch into the end of the brake pipe and continue to form the flare until a solid resistance is felt (fig.4). Return the handle to the original position to withdraw the punch. If the required flare calls for a second operation in Chart 1, rotate the turret until the Op.2 punch is facing and in line with the brake pipe. Operate the lever to complete the form of the flare. Return the lever to the original position to withdraw the punch. Release the clamping screw and swing the clamp open and remove the dies with the pipe.
If necessary a gentle tap on a suitable surface will release the dies from the pipe.
Check the quality of the flare to ensure the pipe did not move during the flaring.
IMPORTANT
The punches and dies supplied for this tool must only be used with this equipment.

Parts support is available for this product. Please email sales@sealey.co.uk or telephone 01284 757500



ENVIRONMENT PROTECTION

Recycle unwanted materials instead of disposing of them as waste. All tools, accessories and packaging should be sorted, taken to a recycling centre and disposed of in a manner which is compatible with the environment. When the product becomes completely unserviceable and requires disposal, drain any fluids (if applicable) into approved containers and dispose of the product and fluids according to local regulations.

Note: It is our policy to continually improve products and as such we reserve the right to alter data, specifications and component parts without prior notice. Please note that other versions of this product are available. If you require documentation for alternative versions, please email or call our technical team on technical@sealey.co.uk or 01284 757505.

Important: No Liability is accepted for incorrect use of this product.

Warranty: Guarantee is 12 months from purchase date, proof of which is required for any claim.

Sealey Group, Kempson Way, Suffolk Business Park, Bury St Edmunds, Suffolk. IP32 7AR



01284 757500



01284 703534



sales@sealey.co.uk



www.sealey.co.uk

CHART 1 FOR BRAKE PIPE FLARING TOOL TURRET TYPE: MODEL NO: PFT02.V2

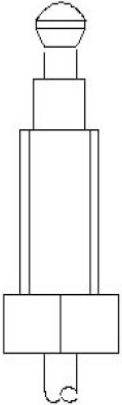
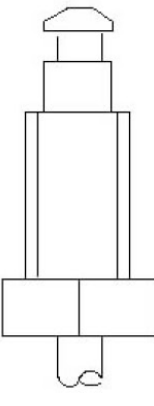
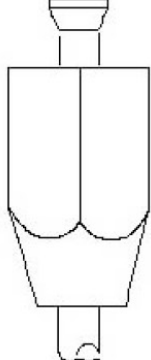
									
SAE CONVEX		113° - 117° DIN CONVEX		SAE DOUBLE					
TUBE ØDIA	OP.1 PUNCH	DIE SET	TUBE ØDIA	OP.1 PUNCH	DIE SET	TUBE ØDIA	OP.1 PUNCH	OP.2 PUNCH	DIE SET
3/16 in	1	4.75-3/16	4.75mm	6	4.75D	3/16 in	1	7	4.75-3/16
1/4 in	2	1/4	6mm	6mm	6mm D	1/4 in	2	B	1/4
5/16 in	3	5/16	8mm	8mm	8mm D	5/16 in	3	8	5/16
3/8 in	4	3/8	10mm	10mm	10mm D	3/8 in	4	D	3/8
1/2 in	5	1/2	12mm	12mm	12mm D	1/2 in	5	9	1/2
6mm	2	6mm				4.75mm	1	7	4.75-3/16
8mm	3	8mm				6mm	2	B	6mm
10mm	4	10mm				8mm	3	8	8mm
12mm	5	12mm				10mm	4	D	10mm
						12mm	5	9	12mm